

HORSE MANURE MANAGEMENT

A Guide for Bay Area Horse Keepers



December 2003

Purpose of this Guide

Proper manure management is an important concern for every horse keeper. Appropriate storage, handling, recycling or disposing of horse manure protects water quality and keeps both horses and people healthy and happy. Good manure management is essential for horses to be accepted as friendly residential neighbors in increasingly crowded suburban settings. Almost forty-five percent of horses nationwide are said to be housed on private residential property. This publication has been developed to provide you with the basic guidelines for best manure management practices and to minimize environmental impacts from your horses or your horse keeping operation. Furthermore, it provides examples of what others are doing to dispose of their manure in the Bay Area, including information based on demonstrations funded under this study.

The reader is encouraged to read the manual "Horse Keeping: A Guide to Land Management for Clean Water," that is being adopted by horse keepers throughout the Bay Area as an effective management tool in a Nonpoint Source Pollution (NPS) control program. Further reading on manure management topics and a glossary of terms are listed in the reference section at the end of this publication.

The "Horsekeeping: A Guide to Land Management for Clean Water" manual is available through the Council of Bay Area RCD's , 1301 Redwood Way, Suite 215. Petaluma, CA 94954-1136. It is available on-line.

Updated 6-2007

ACKNOWLEDGEMENTS

Description of Bay Area Manure Management Program

The Council of Bay Area Resource Conservation Districts (CBARCD) developed a partnership with equestrian organizations, the USDA Natural Resources Conservation Service (NRCS), Region 2 of the State Water Resources Control Board (SWRCB), and four Resource Conservation Districts (RCDs) in Alameda, Marin, San Mateo and Southern Sonoma counties, to address horse keeping and potential water quality problems that might be attributed to horses. Funding was secured through the State Board with 319(h) funds. The goal of the program is to minimize or eliminate potential non-point source pollution from horses that may enter Bay Area creeks and streams while improving and protecting water quality through best management practices. The first phase of the project, which concluded in June 2000, looked at conservation practices that apply to equestrian facilities and resulted in a manual on best management practices for horse keepers. The second phase of the project was a grant program (2001-2003) that specifically addressed on-site manure management at equestrian facilities. During both phases, educational materials were produced and workshops and hands-on demonstrations were carried out. This transfer of appropriate information, practices, and technology to horse keepers helps achieve the overall goal of fostering long term stewardship of our many and varied natural resources in the Bay Area.

Lead Author

Marc Buchanan, PhD
Buchanan Associates, Scotts Valley, CA

Contributing Editors

Jeff Creque, Golden Bear Land and Water
Adda Quinn, EnviroHorse and San Mateo RCD Equine Committee
Tristy Schewe, Marin Resource Conservation District
Jason Sweeney, Southern Sonoma County Resource Conservation District

Core Work Group

Mike Ednoff
Krissa Lebacqz
San Mateo Resource Conservation District

Amy Evans
Alameda County Resource Conservation District

Melissa McCoy
Tristy Schewe
Marin Resource Conservation District

Chris Delaney
Jason Sweeney
Southern Sonoma County Resource Conservation District

Dave Nicholson
Marin County Stormwater Pollution Prevention Program

Funding for all publications in this series was provided in part by the U.S. Environmental Protection Agency pursuant to Assistance Agreement No. C9-989697-00-0 and any amendments thereto which has been awarded to the State Water Resources Control Board for the implementation of California's Nonpoint Source Pollution Control Program. The contents of this document do not necessarily reflect the views and policies of the USEPA or the SWRCB, nor does mention of trade names or commercial products constitute endorsement or recommendation for use.

Defining NonPoint Source Pollution

Nonpoint source (NPS) pollution is defined as the accumulation of small pollution sources (like manure piles or paddocks) and single pollution events that as a whole cause significant degradation to water quality. The term nonpoint contrasts with point sources of pollution that originate from a discharge, such as from a sewage plant or factory. Nonpoint source pollution is not as definable and includes runoff from roads, parking lots, and other paved surfaces and urban areas. Rural runoff from farms, stables, and ranches may also contribute to nonpoint source pollution and needs to be controlled. In the 1986 EPA Report to Congress, the nation's remaining water quality problems were largely attributable to pollution from non-point sources including runoff from soil erosion, nutrients, and chemicals (CAST 1992). The initial approach being undertaken nationally by the government is to seek voluntary compliance to eliminate nonpoint sources of pollution, while requiring permitting and utilizing enforcement actions for the large and significant sources. In 1999, EPA reported that while many water bodies have been cleaned up substantially, 40% of the Nation's waterways assessed by states still did not meet water quality goals for fishing, swimming or both (www.epa.gov/owm/finafost.htm). The program to eliminate NPS pollution is being promoted through education that encourages voluntary participation and stewardship in improving water quality. This publication has been created as part of that educational effort.

Table of Contents

Purpose of this Guide
Acknowledgement

1. Horses and Manure	7
2. Manure Management Options	8
2.1 Guidelines for Handling and Temporary Storage of Manure	8
Manure Storage	8
Minimize Runoff	9
Setbacks and Buffer Strips	10
2.2 Pasture Management	10
Pasture Buffer Guideline	11
2.3 Land Application	11
Land Application Guidelines	11
2.4 Off-site Disposal and Recycling	13
3. Composting Manure	14
3.1 On-site Composting	14
A Manure Pile Does Not Constitute Composting!	14
Composting Solves Problems and Increases Value	14
3.2 Basic Composting Theory and Practice	15
Compost Requires Management	15
Dealing with Woody Bedding Materials	15
Hands-On Experimentation for the Novice Composter	17
Five-Gallon Bucket Test	17
Does Your Manure Bedding Mix Require Additional Water?	17
What Compost Method is Best for You?	18
3.3 Size of Operation Determines Site and Technology	20
Compost Technologies and Management	22
Managing the Compost Process	23
Monitor Compost Temperatures	24
When is That Compost Done?	25
Laboratory Analysis of Compost	25
3.4 Composting Economics	25
3.5 Composting Summary	26
4. On-Site Composting Case Studies	27
4.1 Case Study #1	27
4.2 Case Study #2	29

Table of Contents

4.3a	Case Study #3	30
4.3b	Case Study #4	32
4.4	Case Study #5	33
5.	Glossary	35
6.	References	36
7.	Sources For Further Technical Assistance	38

Tables and Figures

Table 1.	Average nitrogen, phosphorus, and potassium content (NPK) of horse manure and manure with bedding	7
Table 2.	Average amount of storage required for manure	9
Table 3.	Average manure application and land base area requirements for pasture crops	12
Table 4.	Separation distance from streams, rivers, and lakes for land spreading of manure	13
Figure 1.	The aerobic compost process	16
Figure 2.	Example of idealized compost site details	21
Figure 3.	Cross-section of an idealized detention basin	22
Figure 4.	General design for horse manure compost bin	23

HORSES AND MANURE

University researchers have determined that, on average, a 1,000 pound (lb) horse can generate 8-10 tons of manure a year, accumulating at the rate of approximately 0.75 cubic feet per day. This equates to roughly 12-15 cubic yards of manure annually. Daily manure may consist of 30 lbs of feces plus 20 lbs of urine. Manure contains plant nutrients, soluble and insoluble organic compounds, and microorganisms. Additionally, at an average of 1 cubic foot per day, bedding can add up to 13.5 cubic yards of waste materials annually to the manure. Manure and used bedding must be properly handled, stored, and disposed or recycled.

Manure has a long history of use as a soil amendment and alone can be a valuable source of nutrients for plant growth. The composition of this waste material varies depending on the type and quantity of bedding used, age and function of the animal, type of feed, and how the manure is stored. Use of bedding, such as softwood shavings, sawdust, straw, or other organic materials will tend to reduce the total nutrient content per ton. Conversely, the addition of large amounts of wasted hay or other feed will increase the nutrient content of the manure and bedding. Table 1 gives an average nitrogen, phosphorus, and potassium (NPK) content of horse manure alone and with bedding. Horse manure also contains many other plant macro- (e.g. calcium and magnesium) and micro- (e.g. copper and zinc) nutrients.

Table 1. Average nitrogen, phosphorus, and potassium content (NPK) of horse manure and manure with bedding (dry weight basis)

NUTRIENT	MANURE		WITH BEDDING
	%	LBS./ TON OF MATERIAL	
Nitrogen (N)	0.95	19.0	11.0
Phosphorus (P)	0.30	6.0	2.20
Potassium (K)	1.50	30.0	1.30

As shown, horse manure can be a good fertilizer. Horse manure is underutilized as a soil amendment. It can build soil organic reserves, resulting in improved water-holding capacity, increased water infiltration rates, and improved structural stability. Manure can decrease the energy needed for tillage, increase root penetration and the ability of a seedling to sprout, stimulate growth of beneficial soil microbial populations, and increase the number of beneficial organisms such as earthworms. Horse manure is prized by home gardeners and commercial nurseries because it is less dense than other types of animal manure. It is dry with a high carbon to nitrogen, or C:N ratio. It composts well alone or as an amendment with wet cattle or poultry manure. It has low odor potential, and decomposes rapidly, especially if it is not mixed with large quantities of bedding.

For more information and web sites on horse manure as a soil amendment, please refer to list of references supplied in this guide or contact your local RCD, NRCS, or other technical information provider also listed in this guide.

2. MANURE MANAGEMENT OPTIONS

In many locations in the San Francisco Bay Area, horses are confined in small paddocks due to limited land areas available for full-time pastures. Therefore, manure and bedding are removed regularly and may potentially accumulate in large piles, rather than being naturally spread in random patterns over a pasture. Manure piles poorly placed in proximity to road ditches, other drainage swales, and creeks or streams can pose risk to water quality.

The following guidelines, along with additional information and reading contained in the References section, can assist the horse keeper with the handling and storage of manure.

2.1 Guidelines for Handling and Temporary Storage of Manure

Care and feeding of horses in small, confined areas requires regular removal (daily, if possible) of manure from stalls and paddocks. Stalls and paddocks should be kept clean and dry. Decomposition of manure starts as soon as it's voided. Decomposition rates of manure depend on handling and storage methods. Horse manure stockpiles should be kept compact and moist to prevent excessive nutrient losses. When left in a loose heap or scattered piles, it loses nitrogen rapidly to the atmosphere in the form of ammonia. Urine has a much higher nitrogen content than manure and bedding and these nutrients are more readily available as fertilizer. Bedding used in horse stalls absorbs and holds this valuable component well. Care should be taken to leave behind usable bedding when manure is removed from stalls. Some stables encourage separation of manure-with-some-shavings and pure manure so that separate storage and recycling areas can be established similar to approaches used with yard waste. Such separation aids manure composting by reducing the overall volume of waste and the time needed for the composting process. This may significantly reduce the overall costs for disposing of the waste or compost.



Wheelbarrels with fat tires are a basic manure management tool

Manure Storage

Table 2 shows average volumes of manure and manure plus bedding generated by a typical horse facility over a one-year period. Storage areas must be designed to safely contain the total volume of manure anticipated to be generated within the storage period. For example, a storage area designed to contain all the manure and bedding from one horse for an entire year should be large enough to contain up to 20 cubic yards of material. This could be accomplished in a storage area measuring approximately 12 x 12 feet, assuming material is piled to a depth of 3 to 5 feet. If, however, manure is moved from storage to a composting area on a monthly basis, the storage area could be designed to contain one twelfth that volume, or about 2 cubic yards. In that case, the storage area could be as small as 3 x 6 feet, with a pile height of 3 feet.

Storage sites should be located so that loading and unloading is convenient. Surface runoff should be prevented from entering the storage area from the surrounding land, and runoff of contaminated water from the storage area should be prevented entirely by roofing or covering the storage area with a tarp. If water does leave the storage area, it should be channeled to a containment area, grassed waterway or similar structure to insure it does not enter waterways or otherwise contaminate clean surface or ground water. Clean surface water, including roof runoff, should not be commingled with manure-contaminated water.

As can be seen from table 2, larger horse facilities require much larger storage capacities. In such cases, containing and covering manure may be impractical, requiring storage on open areas. In such cases, the proper management of site run on and run off is essential.

Table 2 Average amount of storage required for manure *

NO. OF HORSES	MANURE*		MANURE W/BEDDING*	
	250 DAYS	YEAR	250 DAYS	YEAR
	CUBIC YARDS			
1	7	10	12-14	17-20
5	35	50	60-70	85-100
15	105	150	180-210	255-300
25	175	250	300-350	425-500
40	280	400	480-560	680-800

*Assumes 0.75 cu.ft. of manure/day and 0.50 to 0.75 cu.ft. bedding/day (a cube 3-ft. x 3-ft. x 3-ft. is 27 cu.ft. and is equal to 1-cubic yard).

Minimize Runoff

Encourage stormwater infiltration into the ground on your property to reduce runoff, and thus the **potential** transport of nutrients and pathogens from manure to water bodies. Small grassed depressions in your pasture can act as detention basins that capture water, filter sediment and nutrients from the water, and encourage infiltration. Divert storm runoff from high traffic areas and paddocks by constructing grassed swales or diversions. If necessary, due to predictable high rainfall, a berm should be built behind and around the storage area to prevent runoff from draining directly into water bodies. **Never** store manure in the pathway of storm water runoff that is heading downhill to a drainage or stream.



An impermeable surface, graded to control runoff.

A basic management and stewardship practice is to “Keep Clean Water Clean.” For example, barns should be equipped with gutters to direct water away from paddocks and manure storage

areas to dry wells, clean water ponds or grassed waterways. Keeping clean water clean is easier than managing and treating it once it has become contaminated with manure or sediments.

Setbacks and Buffer Strips

In addition to reducing runoff potential through the use of berms, roofs, etc., maintain a vegetated buffer strip along ditches, stream banks and ponds wherever possible. Such buffers are highly effective at filtering sediment and nutrients from surface waters flowing through them. Safe buffer widths can vary, depending on slope, soil type, type of vegetation and other factors. A minimum buffer width of 50 feet is recommended in most cases, but 100 feet may be needed along reservoirs and public water supply tributaries. Where buffers are not vegetated, or storage area runoff controls are inadequate, the USDA-NRCS recommends buffers up to 200 feet wide. This may be impractical, or impossible on some sites. Be sure to check local regulations for specific guidelines and required permits, if any.

2.2 Pasture Management

Management of pastures is much different from management of paddock and stall areas. Pasture, while not essential, can provide an inexpensive supply of high quality feed with all the protein, vitamins, and minerals needed by horses. However, pastures can vary greatly in productivity. Pasture productivity is related to: (1) the number of animals per unit area; (2) vegetative makeup of the sod; and (3) the natural fertility of the soil. Too often, horse pastures are grazed throughout the growing season without rotation. The stocking rate for horses is site-specific, with soils, slope, irrigation, rainfall, and management all playing a part of what the pasture can support.

Horses can do a fairly good job of distributing manure. However, concentrated droppings from horses can suffocate or stunt plants underneath them. To maximize pasture production, drag or harrow the pasture to break up the droppings and more evenly spread the manure. To avoid concentration of manure in one or more isolated areas, the horse keeper should encourage even grazing. If horses in the pasture receive supplemental feed, try moving the feeding location around. Keep horses out of streams, lakes, ponds, and wetlands. If you cannot completely fence your horse out of these areas, build water crossings to limit access as much as possible. Consider alternative water sources, such as troughs or an automatic watering system.



Pastures should be managed to control parasites.

Horses are susceptible to more species of internal parasites than any other kind of livestock. Seldom are the outward symptoms of internal parasites evident in the mature horse, that owners may not be aware of infection. Uncomposted horse manure disposed on horse pastures risks spreading internal parasites. Fortunately, only a few internal parasites present a problem (ascarids, strongyles, bots, pinworms). Fresh manure should only be spread on inactive pastures. Ideally with small pastures, the horse should be rotated to a fresh area about every two weeks to break up the life cycle of internal parasites.

Pasture Buffer Guideline

Maintain a 100-foot vegetated buffer strip near reservoirs and along public water supply tributaries and a minimum 50 foot buffer from banks of other streams and ponds.

2.3 Land Application

Where enough land area is available, manure can be safely and efficiently used as a soil conditioner to improve cropland, landscape plantings or pastures. On cropland, a two inch layer of manure incorporated into the surface soil immediately after spreading can help improve soil fertility and help prevent losses of nutrients, particularly nitrogen, from the manure to the atmosphere. Manure can be used as a two to four inch surface mulch in landscaped areas to suppress weed growth and conserve soil moisture.



Finished compost can be used on site as a beneficial mulch.

On pasture areas, manure can be spread evenly to a depth of one half to one inch without suppressing pasture vegetation, ideally just prior to fall rains. Tillage in permanent pastures is generally undesirable, as it leads to destruction of the existing sod and the need for reseeding and reestablishment of pasture vegetation before grazing can resume. Because manure can contribute to contamination of runoff during heavy rains, be sure to maintain appropriate buffers between water bodies and areas where manure is applied, whether spread on the surface or tilled in to the soil.

Land Application Guidelines

Knowing the nutrient content of stored manure will increase the potential for effective absorption of manure nutrients by soil and plants and reduce potential for leaching or runoff risk. Although each source of horse manure will vary, a standard "NPK" value (Table 1) can be used to determine the number of acres needed to properly spread the horse manure. When using stored manure in place of purchased fertilizer, you may wish to have a more accurate estimate of its nutrient content. Manure can be sampled, packaged, and sent to a testing laboratory for nutrient analysis. (*Contact your local RCD, NRCS, or Farm Advisor for further technical assistance and locations of laboratories*).

Calculating manure application rates is a mathematical exercise that aligns the nutrients supplied in the manure and the nutrient demands of the crops (Table 3). Not all of the nutrients in

manure are available for plant use. For example, the percentage of the total nitrogen available is a function of the method of manure application and management as well as the age and chemical composition of the manure. For horse manure, nitrogen content typically ranges from 35 percent of the total nitrogen if the manure is spread and left on the soil surface, to 60 percent if the manure is spread and worked into the soil within a day. Phosphorus and potassium uptake is commonly assumed to be 60 and 90 percent of the total available, respectively. If large amounts of bedding are present in manure, it will have a high carbon and low nitrogen content which can tie up nitrogen temporarily until the bedding decomposes. A supplemental source of nitrogen could be needed to offset this nutrient imbalance.

Table 3. Average manure application and land base area requirements for pasture crops.*

FORAGE CROP	ANNUAL MANURE APPLICATION	LAND AREA REQUIRED
	<u>TONS/ACRE</u>	<u>ACRES/HORSE/YR</u>
Red Clover	10	0.8
Ryegrass	11	0.8
Tall Fescue	13	0.6
Wheat Grass	2	

*Adapted from Davis and Swinker, 1996 (assumes 8 tons of manure/yr).

Example 1 (from Table 3)

A horse keeper with 2 acres of land intended for seeding of tall fescue and ryegrass would require:

$$12 \text{ tons manure/acre} \times 2 \text{ acres} = 24 \text{ tons of manure}$$

Example 2

A horsekeeper has 2 acres of established ryegrass and tall fescue which can utilize nutrients in 12 tons of manure applied per acre. This pasture can safely “recycle” the manure from how many horses?:

$$2 \text{ acres} / 0.8 \text{ acres/horse} = \text{annual manure from 2.5 horses}$$

Certain fields or portions of fields must be excluded from manure application based on environmental precautions. Some guidelines are listed in Table 4. After you determine application rates, you need to make some decisions about the method of application. The primary goal is to apply manure uniformly throughout the field. The timing of the manure application is also important. The ideal scenario is to spread manure in the spring. This supplies nutrients for the upcoming growing season and minimizes the amount of time for potential losses before crop uptake. Avoid applying manure in winter. Manure applied during the rainy season can be susceptible to leaching or runoff.

Table 4. Separation distance from streams, rivers, and lakes for land spreading of manure.*

Slope (%)	Soil texture	Setback (feet)
0-3	Sand-sandy loam	50
3-6	Sand-sandy loam	100
0-3	Loam to clay	50
3-6	Loam to clay	150
Over 6	Sand-sandy loam	200

*Setbacks will vary depending upon local regulations, the condition of vegetation in the buffer, soil type, slope, and rainfall regime. These are generalized figures and as such, the reader is advised to first check with their local planning department, NRCS, or RCD field office.

2.4 Off-Site Disposal and Recycling

Unfortunately, significant quantities of horse manure and bedding are hauled to landfills each year. At the same time, gardeners, landscapers, and small farms in your area may be seeking organic amendments. Fresh manure and bedding may be preferred by some, but may raise concerns due to the potential presence of pathogens and weed seeds. Properly aged manure from your storage area might be more preferable to some. Your manure and bedding is a potentially valuable resource. There may be ways to give or truck it away for uses that cost less than land-filling and are more environmentally desirable. Disposing of manure to a landfill can be quite costly due to trucking costs and the ever increasing “tipping fees” charged at disposal sites. In addition, all landfills are trying to extend their "life" through recycling programs and horse manure is a recyclable waste.

Another alternative is to find a commercial composting operation close to where your horses are kept that may accept your manure and bedding for less cost than a landfill. Throughout California there are numerous municipal and private operations that compost a variety of organic wastes. The California Integrated Waste Management Board (CIWMB) provides a list of commercial composting sites that may accept your manure and bedding. This information is available on the CIWMB website

(www.ciwmb.ca.gov) or by calling (916) 341-6000. The CIWMB also maintains a website for

the California Materials Exchange

(www.ciwmb.ca.gov/calmax), which links those looking for organic materials with stables providing manure. A final alternative is to work with other horse keepers, equestrian organizations, livestock operations, and your Resource Conservation District, to develop a community or regional composting facility that accepts manure from horse keepers.



Small bin system with space between boards for aeration.

3. COMPOSTING MANURE

Composting may be defined as the controlled breakdown or degradation of organic material into a product known as humus. Composting is an excellent way of disposing and recycling horse manure. Composting manure decreases the volume of waste, makes handling waste easier, and transforms a potential liability into a marketable resource. The following sections describe the basic considerations for composting horse manure.

3.1 On-site Composting

Often, horse owners and managers don't have access to enough crop or garden land to use all of their valuable manure. Composting offers a means of enhancing the material for on-site use while also reducing its volume. While composting takes additional time and expense, it can have a number of advantages depending on the specific needs of your site. Composting can be more expensive than land spreading of manure. However, many who have become avid composters believe that the added benefits of composting far outweigh the costs. Composting of horse manure alone can take 30 to 60 days, while manure with bedding may require as long as 6 months for complete composting.

A Manure Pile Does Not Constitute Composting!

Composting is a **managed** process that accelerates decomposition and conversion of organic matter to stable humus. Composting manure is an effective way to transform waste into a valuable resource for pastures, fields, and/or gardens. During the composting process, a large mass of "hungry" microbes break organic materials into smaller physical and chemical particles and build new organic molecules. Composting is both an art and a science. Good composting practice involves maintaining the optimal environmental conditions for microbial growth (water, air, organic matter or carbon, and nitrogen). Merely piling manure for some undetermined time is not composting!

Composting Solves Problems and Increases Value

Composting can reduce the total volume of manure and bedding generated on your property. Thorough composting will typically reduce the initial volume of material by 40 to 50 percent. Good composting can reduce the risk of manure to water quality by:

- *Reduction and elimination* of microbial pathogens;
- *Reduction* of ammonia-N levels;
- *Reduction* in water-soluble phosphorus;
- *Reduction* of water-soluble organic matter (BOD); and
- *Reduction* in total soluble salts.

In a process called aerobic thermophilic composting, microbial activity creates heat that causes the pile to reach temperatures that can kill weed seeds and eliminate pathogens and parasites. Flies are reduced because breeding conditions are eliminated. Composting removes the odor and results in a valuable product that can be sold. The finished compost is a valuable soil amendment, adding nutrients, organic material, and texture to the soil.

3.2 Basic Composting Theory and Practice

Composting Requires Management

The basic elements of composting involve maintaining adequate air (oxygen), temperature, and moisture necessary for microbes to flourish. Horse manure and bedding typically contains the correct ratio of carbon to nitrogen necessary for successful composting, although occasionally this may require adjustment. The decomposing manure and bedding in compost is a carbon and nitrogen “converter” fueled by oxygen, high temperatures, and water. In order to function, a compost pile must have sufficient “breathing” spaces for the microbes and allow the carbon dioxide from their breakdown of organic matter to exit. Moisture is key to maintaining a habitat for large microbe populations. Another challenge is to ensure the proper proportions of the materials in the compost. The type and amount of bedding will substantially affect the ease and rate of composting. Less bedding in the compost results in a faster process and a higher quality final product. Different types of organic materials compost differently. You’ll need to customize the process to fit your specific combination of manure, bedding, and other organic materials. You can find the best mixture by developing a clear understanding of the process, accurately measuring materials, and going through some trial and error.



Compost with woody bedding material.

Dealing with Woody Bedding Materials

Typical bedding materials such as shavings and sawdust can create challenges for composting and the production of a quality finished product. Wood is composed of complex organic compounds rather than simple ones. A compound called lignin is an important component of wood because its chemical structure resists decomposition by many microbes that may flourish in a compost pile. In fact, only a small proportion of microbes (predominantly fungi) can completely decompose lignin to carbon dioxide and water. Therefore, the breakdown of woody material is slow even in the most active composting process. Too much woody bedding will result in a lower quality compost product with a high C:N ratio that is less desirable for tilling into the soil. Adding nitrogen to reduce the initial C:N ratio is more cost-effective than adding special microbe inoculants that are on the market and may be necessary in some cases.

Air

In the presence of oxygen, organic material degrades. Approximately two-thirds of the compost piles’ initial volume should be interconnected free air space. Air space allows oxygen to move into the pile while allowing carbon dioxide and water vapor to leave. Horse manure combined with ample wood shavings or straw is porous and very permeable to gases because of varied particle size. Mixtures of manure and sawdust require a slightly higher degree of management to maintain adequate permeability in the compost bulk. If managed properly, however, sawdust will compost faster than coarser bedding materials. Too little air space reduces the oxygen available to the microorganisms while too much air space dries the pile out and prevents it from reaching temperatures high enough to compost effectively.

Carbon and Nitrogen

Horse manure alone will have close to the optimum proportions of carbon and nitrogen that compost microbes require. Carbon is the major component of organic matter (45 to 55 percent) in manure and bedding. A long established “rule of thumb” suggests that a starting carbon-to-nitrogen ratio (C:N ratio) of 25 - 35:1 is optimal for composting. Horse manure may range from 25:1 to 50:1. However, with the addition of bedding, particularly that derived from wood, C:N ratios will be higher as the bedding contains much higher amounts of carbon. Given this reality, manure, hay, and bedding must be relatively fresh for optimal composting so that the microbe-available carbon and nitrogen is high. Alternatively, when bedding such as sawdust, rice hulls, or shavings is used in high proportions, additional nitrogen might need to be added to enhance the decomposition of the woody material. This additional nitrogen might be supplied with fresh grass clippings, hay, or fertilizer.

Temperature

The highest quality compost is produced at internal compost pile temperatures ranging between 131 to 150 degrees F (Rynk, 1992). The above factors of air and water have much to do with achieving these temperatures. At these elevated temperatures, microbial pathogens are destroyed and all but the most hardy weed seeds are killed.

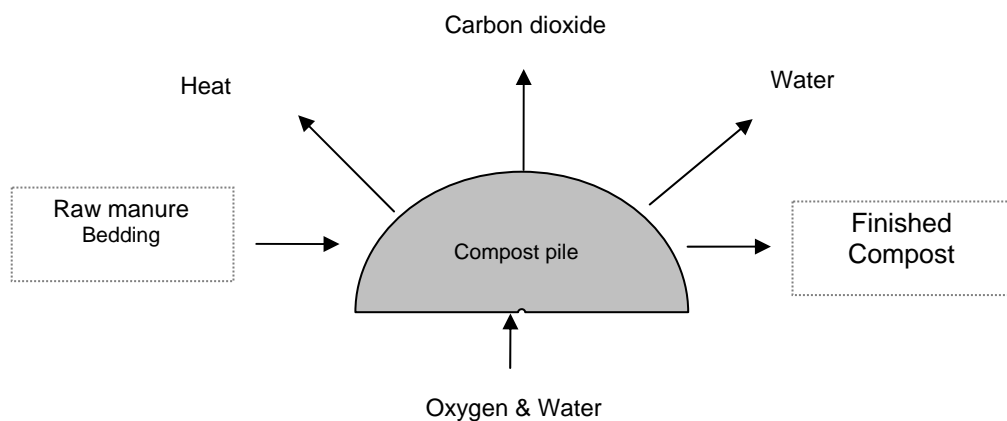

Figure 1. The aerobic compost process

Water

Water is required for good composting. Microorganisms grow best with a moisture content of around 50 - 60 percent by weight of the compost pile (Rynk, 1992). If the compost feels like a freshly wrung out sponge, the pile most likely contains the proper amount of moisture. If water runs out of the pile or if you can squeeze water from a handful of compost, it is too wet. Too much water can reduce the supply of oxygen and allow offensive odors to develop. Closely monitor the moisture level, especially during hot, windy days when as much as 5 percent (water equivalent) of the pile’s total dry weight can be lost. Adding a little water regularly is much better than letting the pile get dusty and dry, then trying to rewet it back to the 50 percent range.



Commercial test kits are available.

Hands-On Experimentation for the Novice Composter

Before you build a small or large compost pile, it might be good to do some additional “homework”. You may want to test your manure and bedding mixture to get an actual carbon and nitrogen value (see sample and testing section). Even if you choose to use the above-mentioned rules of thumb for average C:N ratios, you may find that a direct determination of your mixture’s air space and initial water requirements will be helpful. The following method (from the University of Minnesota Extension Service) can assist the novice composter in “dialing in” the proper aeration.

Five-Gallon Bucket Test

Materials needed:

- ✓ five-gallon pail
 - ✓ one-gallon pail
 - ✓ typical mix of materials to be added to the compost pile (manure, wood shavings, straw, etc.)
-
- Fill the five-gallon pail one-third full with a mixture of typical pre-compost materials. Drop the pail 10 times from a height of six inches onto a concrete floor or solid surface to pack the material. Be careful not to spill any of the compost materials.
 - Add more material to fill the five-gallon pail two-thirds full. Drop the pail 10 more times from a height of six inches.
 - Fill the five-gallon pail up to the top. Drop the pail 10 times from a height of six inches. Fill the five-gallon pail to the top once again.
 - Add water to the five-gallon pail, keeping track of how much you can fit in before it overflows.
 - If you can add 2-1/2 to 3 gallons of water, you have adequate free air space. If not, you need to add more bulking material, such as straw, coarse wood chips, or shredded bark.
 - If you can add more than 3 gallons of water, you have too much free air space. The particle size must be reduced by shredding or grinding the compost materials or by mixing finer materials into the compost.
 - Retest new mix.

Does Your Manure Bedding Mix Require Additional Water?

Optimal starting moisture for composting is between 50 and 60 percent. Fresh manure alone will be at the optimal moisture level for decomposition. However, the addition of varying amounts of dry bedding, even with urine, can reduce moisture substantially. Additionally, time spent in a storage area in the middle of the summer can reduce moisture even further. Composting in the dry summer season will inevitably require additional irrigation, but you can reduce that need by being certain that your starting moisture is correct. The following is a simple method to determine the moisture in your manure-bedding mix.

Using any reasonably accurate weighing device, weigh out a full 1 or 2 gallon bucket of the mix. Record this as the “fresh” or “wet” weight of the material.

Depending on your preference-tolerance level, select a means to dry this material. Obviously an oven is the best choice (but only the most dedicated will bake a manure cake!). The material could be placed near a hot water heater, in a greenhouse, or anywhere that will assure that the majority of the moisture will evaporate. Re-weigh the material and record this as the dry weight. Calculate the moisture content on a dry weight basis:

$$\frac{(\text{Wet wt.} - \text{Dry wt.})}{\text{Dry wt.}} \times 100 = \text{Moisture \%}$$

What Compost Method Is Best For You?

If you talk to enough experienced composters, you may find that each one adheres to their own “best method”. Composting is both art and science, a balancing act so-to-speak. You will soon discover that the appropriate composting method is determined by the realities and size of your site, the number of horses, the type of equipment and labor you have available, the intended use of the final product, and many other factors specific to your needs or goals. The following section describes some basic composting methods that can be applied to any size project. You will find helpful tips on deciding the appropriate compost method or technology that fits the scale, available equipment, and costs specific to your site.

Aerobic Thermophilic

This is the composting method assumed and described by many technical resources and guides. The approach requires that oxygen availability is managed to provide optimal conditions for predominantly aerobic (oxygen requiring) microbes. The term thermophilic refers to a group of fungi and bacteria that are so active in breaking down organic matter, that they create significant quantities of heat. These microbes are capable of functioning in temperatures up to approximately 160-165 degrees F. Their oxygen demand is quite high and thus this method requires your manure-bedding mixture to have the optimal physical characteristics that promotes rapid infiltration of oxygen and rapid loss of carbon dioxide.

Aerobic composting methods also require additional management to assure not only adequate oxygen levels, but exposure of all of the composting material to the thermophilic temperatures (>131 degrees F)(CIWMB Website). Therefore additional aeration is often required. This method may utilize your back and shovel or garden fork, a front-end loader, a specialized compost turner, or a system of manifolds, pipes, and blowers (active aeration or aerated static pile method, *see On-Site Composting Case Studies*).

The numerous advantages of this method are:

- ✓ Most pathogens exposed to thermophilic temperatures for periods of 24 hours to weeks at a time are destroyed;
- ✓ Decomposition is rapid and volume reduction occurs quickly;
- ✓ And less time and space are required in comparison to slower methods.

Excessive aeration can lead to large losses of nitrogen as ammonia gas and lower product quality. Piles must be built to an appropriate size that retains (insulates) heat, but not so well that temperatures rise so high as to allow for spontaneous combustion. Compost fires can occur when piles or windrows are too large (overly insulated), not aerated frequently, and when moisture levels decline below 35 percent.

The aerobic thermophilic method is often the preferred method for producing a safe and valuable compost product capable of a wide range of uses.

Anaerobic Composting

Composting can also be accomplished without efforts to maintain aerobic conditions. In reality, even in an aerobic compost pile, there is a significant amount of anaerobic decomposition occurring. However, the major by-products of completely anaerobic decomposition are different than those produced by aerobic composting. More methane (CH₄) is formed than carbon dioxide (CO₂) and ammonia levels (inorganic nitrogen) tend to increase in proportion to organic nitrogen forms. A wide range of other occasionally objectionable odors like hydrogen sulfide and other organic compounds are formed.

Nonetheless, anaerobic composting may be attractive in certain situations. The advantages include less time, equipment, and associated costs than with maintaining aerobic conditions. Although the time required to complete anaerobic composting may be longer than the aerobic process. There will be less or no reduction of microbial pathogens, fly breeding, or parasite eggs, and there is a greater potential for odor generation. Space requirements will be greater due to longer composting time and the product may be less acceptable to certain users. For these and other reasons, anaerobic composting is not recommended.

Vermicomposting

This “passive” composting method adds earthworms, or more specifically manure worms, to a manure-bedding mix. Horse manure has been a choice “food” for bait worm producers and the product derived from vermicomposting has advantages over “traditional” aerobic composts. Vermicomposting allows constant additions of fresh material to the pile or windrow. The process must remain largely aerobic and high temperatures must be avoided. Therefore, piles, windrows, or beds must be small enough to allow any accumulated microbial heat to be lost quickly to maintain a favorable habitat for worms. The worms best suited for this method are manure worms or red wigglers, naturally found in organic matter rather than soil. They reproduce quickly in large numbers and don’t mind being “crowded” as long as fresh food, moisture, and oxygen are adequate.

The advantages of vermicomposting include:

- ✓ Minimal amounts of equipment are required;
- ✓ Aerobic conditions assure limited odors;
- ✓ Fresh manure can be added daily, weekly, or monthly;
- ✓ Volume reduction may be as high as aerobic thermophilic methods; and
- ✓ The final product has a higher fertilizer value and smaller particle size than typical composts, and is very acceptable for a wide number of uses.

Unfortunately, pathogen reduction may be not as great or consistent, space requirements may be excessive, and compost piles or windrows may need to be covered or lined. Initially worms must be purchased. Worms can be quite intolerant of excessive moisture and even noise. Mass migrations out of compost piles occur and the worms are a favorite food of many below- and above-ground predators.

For more information of these basic composting methods, please refer to list of references supplied in this guide or contact your local RCD, NRCS or Farm Advisor for technical information.

3.3 Size of Operation Determines Site and Technology

You should consider the following factors when determining whether composting is appropriate and what method and technology is right for you:

Size - There must be adequate space available to handle the anticipated volume of manure and bedding while providing equipment access and work space. You should consider accommodating an area large enough for active composting and temporary storage of final compost product.

Permit Requirements - If you have a large operation, you should check with your local enforcement agency or planning department to confirm permit requirements for a compost operation. More than likely you will at least need to submit a manure management plan and keep minimal records (although current State regulations state that more than 500 cubic yards of material on site at one time or more than 1000 cubic yards produced per year will trigger the need to obtain a permit for your composting operation) (CIWMB website). A larger stable will likely already have some type of operating permit that allows for composting as a manure management alternative. If not, be prepared to educate your local agency and demonstrate that you are aware of and will maintain strict management controls to protect the environment and the interests of your neighbors. California state composting regulations are contained in Title 14, Division 7, Chapters 3.1 and 5.0 of the California Code of Regulations. For operations employing the aerated static pile method, installation of electrical service and equipment may require additional submissions and inspections.

Site Requirements - Your site must not only be sized appropriately, but the operating surface should allow year-round access and minimize the risk of leaching into groundwater. Bare soil is usually not acceptable unless it is a fine clay that can be compacted well and does not receive heavy rainfall for long periods of the winter. Typically, a low permeability crushed rock or rock dust surface, and concrete or asphalt pads may be required. The site or pad should be on flat ground or a very gentle slope and allow for uniform drainage. Runoff from the site should be contained or conveyed to a settling pond or vegetated filter strip. The site should be a minimum of 100 feet from surface water bodies or located downhill from a water body. The site should not create “viewshed” issues for neighbors and minimize complaints about odor and dust. Figure 2 gives an example of some of these site details.

Water Supply - Access to water for moisture management and fire safety during the dry season is essential. Water quality should meet the minimum standards for crop irrigation. If you are unsure have your water source tested.



Access to a water supply is critical when locating a compost site.

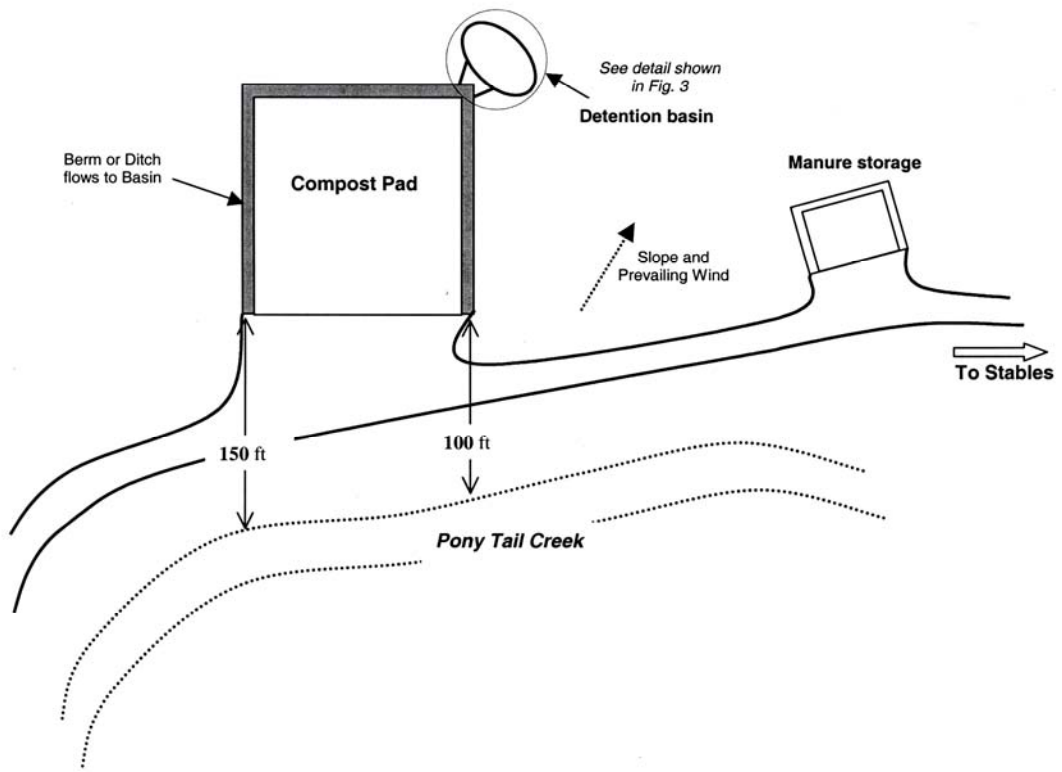

Figure 2. Example of idealized compost site details

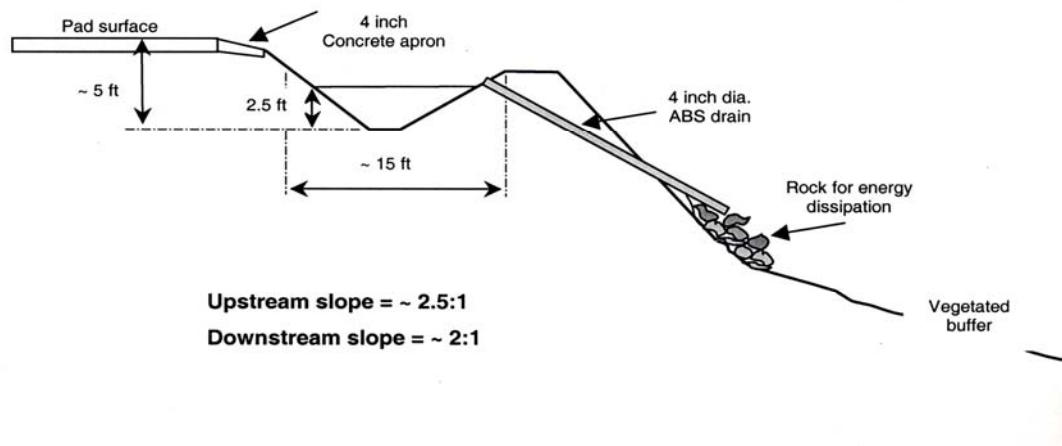

Figure 3 Cross-section of an idealized detention basin

Compost Technologies and Management

There are several ways to design an on-farm composting system and no single one is appropriate for all sizes and types of facilities. However, any system should consist of the following basic components:

- A staging or storage area for raw manure, away from creeks and drainage;
- A set of bins or free-standing piles large enough to maintain elevated internal temperatures;
- A mechanism for turning the piles or moving the compost from bin to bin, such as hand labor for small operations or a front-end loader for larger areas; or
- A designed active aeration scheme utilizing manifolds and blowers; and
- A water faucet or a pump/water tank combination, and a spray nozzle.

Bins

For small operations, constructed compost bins may be the appropriate approach (Figure 4). A series of bins may be necessary for the one horse operation and can be scaled-upwards (within reason) for operations with less than five horses. Size of the pile does matter. Bins 4' x 4' x 5' tall, constructed from 2" x 6" (untreated) boards and heavy-duty posts can be adequate; however, bin design and dimensions will vary with amount manure generated (Figure 4). Some have even used pallets as a material to construct bins. Bins with a wooden floor with small spaces between boards that allow air to move from underneath the pile perform better than bins built directly on the ground. Laying flat drain tile on the wooden floor will further enhance air-flow. Each of these bins should easily hold 1.5 tons of horse manure. When aeration is needed, the material is moved from one bin to another. If your horse manure fills up more than six bins of this size or slightly larger, you may want to consider a windrow composting system.

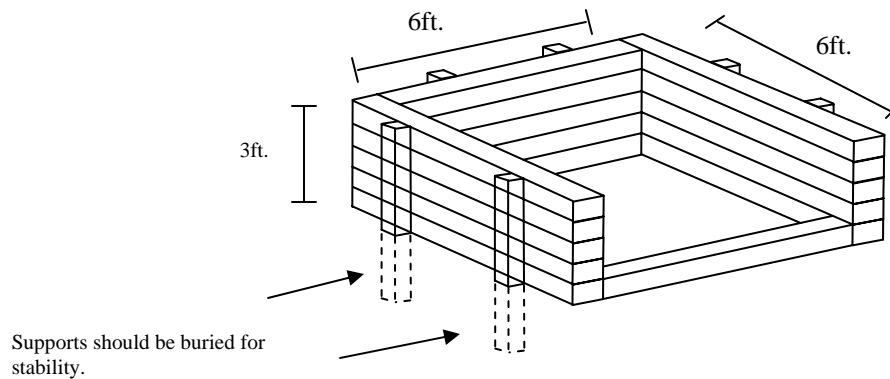

Figure 4. General design for horse manure compost bin

Windrows

For larger operations, a windrow approach will be the most appropriate means to perform aerobic thermophilic composting. Generally, these windrows or piles should be no more than 7 to 8 feet in height and may be of any length that fits with the volume of material generated and the operational preferences of the owner/manager. Windrows and large piles require equipment capable of moving larger quantities of materials. Many stable operations will already have a front-end loader. Dedicated compost turner staff are only appropriate when the quantity of manure is quite large (perhaps > 100 yards per week) and the cost can be reasonably recouped through compost sales or lower disposal costs.

Managing the Compost Process

The critical operational requirements are related to aeration, moisture management, and process monitoring.

Aeration

If you choose to employ an aerated static pile system, you will likely need to refer to established engineering and design criteria. At worst, you may need to hire a mechanical engineer to properly size the system. This is critical to be assured that your active system distributes air evenly throughout the entire composting mass and does not introduce too little air (increased anaerobic locations) or excessive quantities of air while removing too much internal heat, or forcing ammonia from the pile.

When utilizing the turned aerobic method, establish a desired turning frequency of 2 weeks, 3 weeks, or monthly. However, if your operation is large enough to require a permit, you will need to establish a turning frequency in accordance with established pathogen-reduction procedures (CIWMB website). Consulting other folks' "rules of thumbs" may get confusing. Remember that composting can often be very site specific. Be prepared to observe and adjust turning frequency as needed. Ultimately this requires time and cost, so you should strike a compromise between an optimal aeration frequency and the other tasks and labor required at your site. However, you should recognize that there may be times (e.g., following heavy rain-fall) when you may need to aerate, regardless of your schedule.

Turning of compost, whether by back and shovel or mechanical loader, should be done in a manner that allows as much air to be introduced to the material as possible. Realize that you are also attempting to release trapped carbon dioxide and reduce compaction at the same time. Therefore, be certain to allow material to “fall” from your shovel or bucket to expose as much surface area as possible. With a loader, drop the material into the bin or new windrow from the maximum bucket height. With a shovel, give it a good toss.

Moisture Management

The moisture content of the manure and bedding might be adequate in the fresh state, so additional moisture might be unnecessary until the compost is moved or turned. However it may be necessary to add water to the material prior to loading it into a bin or building a pile or windrow. During the dry season, particularly mid- to late summer, have an ample water supply and pressure to “irrigate” the compost as it is turned or moved to another bin. Moisture content can drop as low as 25 percent within 4 weeks of active thermophilic decomposition. To increase the moisture content of compost from 25 percent to 55 percent, add about 20 to 30 gallons of water per 100 cubic feet of compost. For a system in which four bins (1,000 cubic feet each) require additional moisture, approximately 1,200 gallons of water may be needed every time the bins are turned. However, the actual amount of water needed will vary substantially depending on the kind of bedding used, the size of the particles in the bedding, and other site specific factors.

Don’t try to add all the water at once. Instead, use a spray nozzle to deliver the water to the compost as each loader bucket is turned into the bin or new pile. It is easy to verify the proper moisture content. Grab a handful of compost that has been mixed well and squeeze the compost tightly in your fist. You should not be able to squeeze any free water droplets out of the compost, but it should leave your hand slightly wet. If you inadvertently get the compost too wet, don’t panic; just keep an eye on the compost temperatures in that bin and turn the compost if temperatures do not rise in a couple of days. If rank odors emanate from any of the bins, the moisture content is probably too high. Turning the compost will help drive off some moisture, while increasing oxygen and alleviating the problem.

Monitor Compost Temperatures

Checking compost temperature is the easiest and quickest way to keep track of a composting system. Typically, fresh materials will heat up within 24 hours and within 2 to 3 days of correct construction internal temperatures may reach 155 degrees F. A simple long-stemmed thermometer (or two) and some good record-keeping skills are all that are needed. At a point perhaps two feet down from the top of your pile or bin, carefully insert the thermometer halfway into the side of the composting mass and allow the needle or digital display to stabilize. Record the date, time, bin or pile number, location within the bin (e.g., center, northwest corner, etc.) and temperature.



Temperatures should be recorded from a number of locations within the compost pile.

Take temperatures at several locations to average out any odd readings. Sometimes a thermometer will be inserted directly into a cold or wet spot that is not visible from the outside and is not characteristic of the windrow or bin as a whole.

When you are just getting started, measure temperatures at least daily for the first week after the compost pile or windrow is constructed. Then, if temperatures are in the thermophilic range (between 131 degrees and 160 degrees F), the time between measurements may be increased. Twice-weekly intervals are probably appropriate. Declining temperatures early in the composting period likely indicate declining oxygen levels, less than optimal moisture content, or in the worst case inadequate available nitrogen for the microbes. Temperatures immediately after turning and wetting may drop to near air temperature, but they should rebound markedly within 48 hours. The thermophilic stage of decomposition may last for 2 to 6 weeks depending on the starting C:N ratio. Manure containing the proper balance of shavings or sawdust tends to maintain thermophilic temperatures longer than manure alone or with low volumes of bedding, whereas manure with too much bedding can cause temperatures to drop. Keep the temperature data in a handy file to help document to your local enforcement agency and prospective buyers that weed seeds and pathogens will not be a problem in your compost.

When Is That Compost Done?

Typically, when utilizing the aerobic thermophilic composting method, temperature is a key indicator of progress towards finished compost. A standard rule of thumb suggests that compost is finished when there is only a 15 to 20 degree difference between internal pile temperature and the air temperature in the middle of the day. Generally, aerobic composting has three distinct phases: the active, high decomposition phase (thermophilic, 2 to 6 weeks); a slower decomposition phase, (mesophilic, 3 to 12 weeks) carried out by different microbes; and then a curing or finishing stage (4 to 8 weeks), where subtle changes in the biology and chemistry of the compost occur. This last phase creates “mature” compost.

Mature compost is that granular, dark brown, earth-smelling material that we associate with potting soil or other “out-of-the-bag” soil mixes. Compost maturity is extremely important for horticultural and agricultural users who may have interest in receiving or purchasing your compost. While there are commercial test kits and laboratory services available, common sense can also be your guide in determining if your compost is finished.

Laboratory Analysis of Compost

Many users of compost are interested in levels of nitrogen, phosphorus and potassium, total salts or salinity, organic content and, in some cases, micronutrients such as iron or zinc. If your manure management plan includes marketing or giving away the final product, it may be beneficial to have a laboratory analysis of your compost completed from time to time.

3.4 Composting Economics

Maybe you love the idea of making compost and are willing to take on the extra labor and costs to make it happen regardless of economic return. However, if you are not quite convinced, assessing the economics of composting is a good pre-project task. There is no standard guide, as composting economics often come down to the specifics of your operation. Some things are readily apparent at the outset. The purchase of a \$30,000 loader for your one horse in the back

half acre makes no sense, unless you become an equipment operator for hire. If you operate a large stable, you probably already have such equipment. And if you are currently paying to haul your manure to a landfill, you already have a significant cost associated with manure management that could be substantially off-set by producing and marketing compost. The amount of manure and bedding that you must manage is key to determining how cost-effective your composting project can be. Economy is dictated by scale and typically the costs per ton or cubic yard of compost goes down as the volume of manure and bedding generated goes up.



Trucking is the major cost in manure management.

If you are a one horse show with some room and a willing and strong back available, you may only need capital costs for site development and bin construction. If you have a large garden or pasture, you can probably utilize all of each year's compost from your animal's manure and bedding on your property. However, for larger stables there may be significant costs involved for site development, equipment, provision of water and/or electricity to the composting site, and labor. The owner/operator should seriously consider if the costs make sense for the operation. Consider the "avoided" costs associated with composting. How much does trucking and landfill fees cost per year? Compare that to the composting startup costs, including the items mentioned here. Can you save money after considering amortization/depreciation of purchased equipment over five years? Consider marketing your product as another cost offset. Survey the current prices paid for organic soil amendments or mulch materials in your area. Do your math and decide if composting makes both environmental and economic sense for your operation. Additional economic information may be obtained from your local RCD office.

3.5 Composting Summary

You've made it through this brief lesson in composting. Below are some rules to consider and "live by" before and after you become a composter.

- ✓ If you manage a larger facility, be prepared to spend some time educating your clients about your goals for manure management with composting.
- ✓ Prepare your site to ensure the compost area drains well. Ponded water, especially around manure and compost, will cause odor and fly problems. A small box blade or the back of your loader will help keep the area smooth and well drained.
- ✓ Collect manure from the corrals and pens carefully. Try to keep mineral soil out of the manure, and keep track of how many wheelbarrow loads are delivered to your system every day. Try to limit the amount of woody bedding materials that end up mixed with manure.

- ✓ Try to ensure good drainage from any outdoor horse pens from which manure is collected. Muddy conditions give you soil-laden manure, reducing the organic matter content per unit of compost. Instruct employees to keep garbage, plastics, carcasses, and animal health products (syringes, vials etc.) out of the compost piles.
- ✓ Make provisions for adding supplemental water when needed. Shaping the tops of the piles to capture irrigation or rainfall may be helpful.
- ✓ Monitor compost temperatures every few days initially and at least weekly. Temperature alone will not tell the full story, but it can be an indicator of success or of imminent problems.
- ✓ Keep the composting area clean and well maintained. If you have a boarding operation, a good image is vital to ensuring your clients' cooperation and for compost marketing success.
- ✓ Use the finished product in your own landscapes, planters, and gardens. If you use it and like it, your clients will be more inclined to try it.
- ✓ Have laboratory analysis performed on compost samples from time to time. Knowing your product will reassure your compost market and will help you identify ways to improve your system. A routine analysis will include nitrogen, phosphorus, potassium, sulfur, and total salinity. Organic matter analysis adds significantly to the cost, but it will help you determine if manure-harvesting methods are picking up too much mineral soil, which reduces compost quality. If interested in using compost as a bedding material, periodic analysis for pathogens is good insurance.
- ✓ Compost has a value; carefully consider what makes sense to you before you give the compost away. A nominal fee will stimulate interest and the revenue will offset costs.

4. ON-SITE COMPOSTING CASE-STUDIES

Four case studies of compost projects undertaken in the Bay Area are presented below. The case studies are intended to be a guide as to what might be undertaken at your facility to compost horse manure. For further information consult one of the RCD's listed at the end of this publication.

4.1 Case Study #1:

Site/Facility Description

This stable boards 30-40 horses and worked with their local RCD to construct an aerated static pile composting system.

Composting System

The equine facility has constructed a compacted, low permeability gravel pad on which horse manure is managed and composted. The pad measures approximately 88 by 115 feet. It has a

compacted subsoil base, overlain with Mirafi 500x moisture barrier fabric and topped with 4-6 inches of compacted well-graded crushed rock (i.e., road base). The pad has a slope of approximately 2%, which drains surface water runoff into an adjacent vegetated filter strip.

The manure is composted using the Aerated Static Pile (ASP) method, a procedure that was originally developed by the U.S. Department of Agriculture in the 1970s. The system consists of a blower connected to a manifold with a series of four lateral perforated pipes approximately 45 feet in length. The manifold and perforated pipe system sits on the gravel pad and the manure is piled on the perforated pipes. When completed, the manure pile measures approximately 50 feet long by 20 feet wide by 6 feet high, with an initial volume of approximately 200 cubic yards. This represents approximately 30 days of waste for this facility. The blower serves to force air through the manure pile to expedite aerobic decomposition of the manure. The project design incorporates two adjacent manifold systems (systems A and B) that have been constructed to allow for stockpiling of fresh material on one system (B) while manure on the other system (A) undergoes aerobic composting.

After approximately 30 days, the manure pile at system A has completed aerobic composting. Stockpiling of fresh manure at system B over the month is also complete. The manure pile at system A is moved to a third location on the constructed pad to cure. A layer of this composted material approximately 1 foot deep is placed over the manure pile at system B to serve as an insulative cover for temperature retention and as a biofilter to control odors. The blower is then connected to system B to begin aerobic composting, and the landowner begins piling fresh manure at system A. The composting system cycles between system A and system B in this fashion. During the rainy season a waterproof barrier is maintained over the manure piles to prevent compost leachate from reaching any adjacent water bodies.

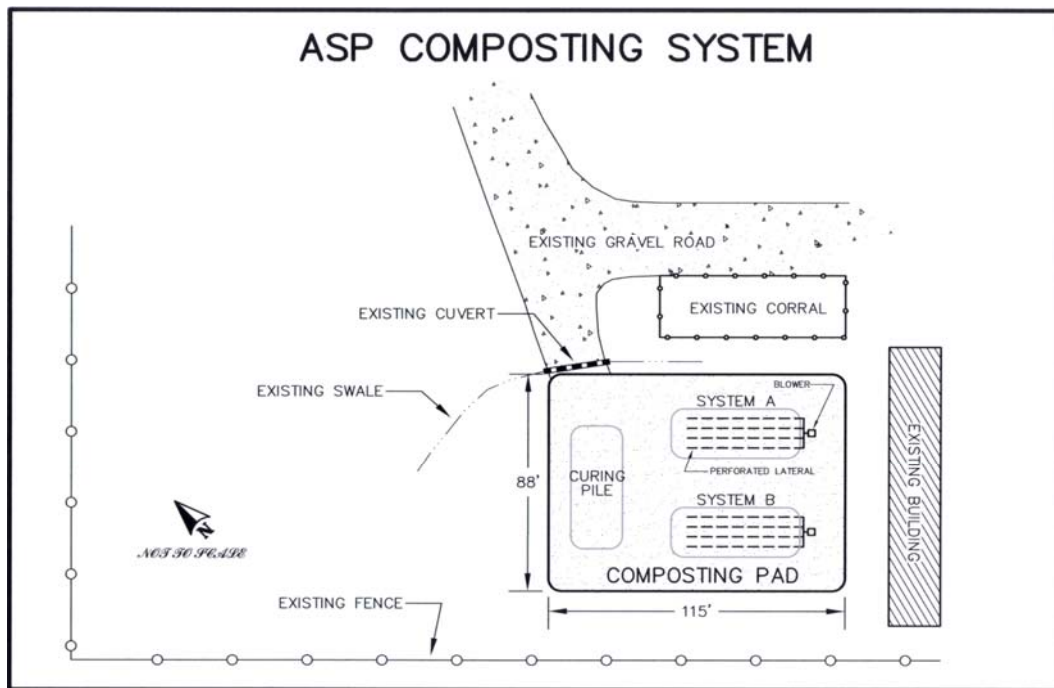

The project landowner is currently using much of the compost as a high quality mulch in their landscaping beds. A marketing plan is also being prepared so that the composted manure can be sold for agricultural or landscaping purposes.

Prior Manure Management Methods

Prior to implementing the composting system, the landowner was stockpiling manure, either giving it away to other landowners or spreading on the open fields of the facility.

Evaluation and Comments From Owner/Manager

The landowner feels that the end product is very usable and good for the environment. There has, however, been an increase in labor and energy costs. The composting project has controlled the odor problem completely and is not attracting flies. The landowner summed up by stating that they will have a salable product that will not only offset costs but produce a small amount of income once they've located some buyers. Even with only using the product as a mulch on-site, it is worth the cost savings of no longer having to buy mulch for the facility landscaping.

4.2 Case Study #2:

Site/Facility Description

The local RCD provided technical assistance on a composting project, in conjunction with the facility's expansion plans. The proposed site was adjacent to an existing stormwater holding pond and approximately 100 feet from a creek. Barns and stalls are 100-300 feet from the compost site. The site was first cleared of all existing manure and graded so that all surface runoff would drain across a grass filter strip toward the holding pond. A berm along the creek side edge of the site was established to prevent runoff into the creek, and a horse trail to the creek was seeded, strawed, and wattled. The composting pad was surfaced with gravel to permit wet season use. Regrading and surfacing the main roads into the facility were completed and old, non-functional ditches and culverts were repaired or eliminated. Gutters were added to the roofs of a covered riding arena and a few older barns so that the clean roof runoff was channeled to energy dissipating rock rip rap above the creek. This significantly reduced the volume of clean water going through the manure compost site and into the holding pond. Unfortunately, local regulations required channeling the clean roof water into the holding pond through a grassed swale which subsequently required enlargement of the holding pond.

Composting System

Composting began in the spring of 1999. A small loader proved inadequate to handle the volume of manure and bedding and turn the windrows. The waste material also has a higher than desired percentage of bedding. Purchase of a larger piece of equipment was not feasible for the stable. Effort was focused on monitoring pile temperatures, moisture and pile configuration to keep the site in an orderly condition and optimize the resulting passive composting process. The finished product is less than desirable due to the high carbon content (undecomposed shavings) and does not meet the criteria for finished compost at the end of the process. The compost is periodically trucked off site to a local farm.

Prior Manure Management Methods

At the time of project initiation, the facility had recently changed hands. An existing drainage

system diverted potentially contaminated surface water through the manure storage area to the holding pond. The pond was subject to local county monitoring and provided habitat for amphibians, invertebrates and migratory waterfowl. The site was used for manure storage and overflow parking for horse trailers and other vehicles. The site was poorly managed and standing water contaminated with manure from winter rains was a problem. Manure volume held at the site averaged 2,500 cubic yards. A horse trail dropped steeply from the site to the creek.

Evaluation and Comments From Owner/Manager

Overall the operator is pleased with the compost system. Their intention to develop a compost system was a win-win situation as the facility, RCD and County learned from the project. The facility benefited from an ability to hold material on site for longer periods of time due to a 50% bulk reduction resulting from composting of bedding and manure, off-site hauling costs were reduced from up to twelve times a year to two times a year, the facility was able to use a greater volume of finished product on-site, and the project resulted in the facilitation of a good relationship with the County and community. Involvement with the County and RCD helped give the project transparency and credibility. In short, the project demonstrated the owner's commitment to operate the facility in an environmentally responsible manner.

The costs of the compost operation and compost disposal remain a concern. Increased management costs and labor may make the business of manure handling and compost marketing unrealistic for most equestrian facilities. An additional 4-8 hours weekly of labor plus management are needed to operate the facility. The cost of purchase or rental of needed equipment such as a one cubic yard front end loader, manure spreader, and trailer or truck for transporting or aiding in spreading the compost may be unfeasible. The high visibility of the compost site for clients entering the facility is somewhat problematic and may be addressed by landscape plantings to better screen the site. Due to the small size of the equipment, it may be better to have a second compost site closer to some of the stalls. Other options include purchase of a used front end loader, use of a nitrogenous additive to improve the C:N ratio of the raw materials, and incorporation of a forced air system.

The attention garnered by this project and outreach efforts by the RCD have resulted in interest from other stables, horse keepers, other farmers and the county to investigate the feasibility of a regional composting facility where costs of equipment and transportation of manure might be spread across a number of facilities. A demonstration of such a cooperative facility is being proposed.

4.3a Case Study #3:

Site/Facility Description

In Alameda County, a 70-horse boarding and training facility is experimenting with composting approximately 10% of its horse manure, roughly 150 cubic yards annually, using the passive aerated composting method. The manure (and wood shavings bedding) is being composted on a 20' x 50' pad located in a nearly flat grassy pasture (1-2% slope) adjacent to

the barn and horse stalls. The soil at the compost site is a deep gravelly loam (72") and the water table (at its highest level during winter months) is at 20'. Because of the potential for groundwater contamination, runoff and leachate from the compost pile need to be managed. The compost system was designed to protect groundwater and surface water primarily by managing the amount of rainfall that reaches the manure through use of a type of tarp to cover piles that allows the passage of air, but is water resistant. "Clean" runoff from each tarp drains to the graveled sides of the compost pad and then flows just down gradient to a portion of the pasture that functions as a grass filter strip and runoff infiltration area. The filter strip traps any stray particles of manure and utilizes any nutrients that may be present in the runoff.

Leachate, the enriched liquid which can drain downward from a saturated compost pile, will be produced in minimal quantities in the compost windrow because of monitoring of the moisture level of the compost material; when piles have reached the maximum moisture content from winter rain or summer watering the tarps will be put over the piles. Any leachate draining from the pile will be blocked from percolating downward into the soil beneath the compost pad because of the moisture-proof PVC liner (.03" thick) that was sandwiched between the two 6" layers of compacted crushed rock (road base) which comprise the compost pad.

Composting System

The passive aeration system of composting utilizes perforated pipe to bring air into the compost pile. At the compost site, the manure was piled onto the rectangular 50' x 20' compost pad in a 2' thick layer. PVC pipes 20' long and 4" in diameter with two rows of ½" holes running the length of the pipes (these are the pipes used for septic tank drain fields) were placed several feet apart on top of the manure, across the 20' width of the pile. Four to six feet of manure was then loaded on top of the pipes. The ends of the pipes project out from the sides of the pile, taking in air, which flows out through the rows of holes inside of the pipes into the manure, thereby aerating the pile through a "chimney effect". The composting method used at the site is termed "static aerated" because the windrow is aerated without turning or use of blowers. This method requires minimal labor and equipment, but the composting process may take longer. Temperature and moisture-level monitoring is done on a weekly basis and this will dictate whether tarps are needed. The tarps are also effective when moisture needs to be conserved in the piles during the dry, hot summer months.

When compost is ready to undergo the curing process it will be moved to an adjacent space in the pasture; a reduction in volume of material of 30-50% can be expected. Compost is utilized at the ranch as a soil amendment to improve the fertility and water-holding capacity of the soil for the landscaping purposes. It may also be utilized by nearby vineyards and for winery landscaping.

Prior Manure Management Measures

Previous to the experiment to compost manure on-site, manure was hauled out to be further composted with grape pomace for use in a local vineyard.

Evaluation and Comments From Owner/Manager

The facility owner is familiar with composting and wished to experiment with the process on-site. The owner also looks to expand tree plantings at the ranch, and needs the compost for a soil amendment. The owner also wants to participate in conservation activities and to demonstrate water quality management techniques. If the composting project is successful and cost efficient, the pad will be expanded and a greater percentage of the facility's manure will be composted.



This compost method uses perforated pipe to bring air into the center of the windrow. Portable fencing keeps cattle out.

4.3b Case Study # 4

Site/Facility Description

A five acre horse boarding facility, located within city limits and surrounded by a housing tract, is developing a “modular” manure management and composting system using compost bins. Since the facility is planned to grow from less than five to more than 10 horses, the number of composting bins in use will increase as needed. The bins are situated at different points around the ranch where they will be most convenient for loading. They will then be moved, once filled, to different areas of the site for an approximate two month composting period. Compost will be utilized on-site for a native plant nursery, or sold/given away to neighbors in the vicinity.

Composting System

The facility owner is using 4' x 4' x 4' wooden bins (originally built for use during almond harvesting) for composting manure and bedding. The bins are very sturdy and constructed in such a way that they can be picked up and moved with a forklift. Daily stall cleanouts are placed into a bin on top of six inches of dry wood shavings that have been placed in the bottom to absorb liquid from the composting manure. Three or four, five-foot lengths of PVC plastic pipe 4" in diameter with two rows of holes drilled down the length are situated vertically in the manure in the bins to improve aeration. When the bin is filled so that manure is piled one-foot above the rim, a water-resistant, breathable tarp is used to cover the bins to help the composter control the moisture content of the manure; once the manure has reached the optimal point of dampness (from rain or watering) the tarp can be deployed to cover the

manure and the outside of the bin sides. The bins can be set onto cinder blocks during the wet season if needed. The tops of the pipes are slightly exposed above the manure, and will ventilate through the tarp. This will also prevent flies from accessing the manure. Pile temperature and moisture level is monitored weekly.

Prior Manure Management Methods

When only 2-4 horses were at the site manure was tilled into the soil, and some of the material was used for soil mix for a small native oak nursery at the site.

Evaluation and Comments From Owner/Manager

The landowner of this very old, historical ranch which has had horses on it for over 125 years is very interested in developing a small scale, low visibility, modular manure management system which will not impact the surrounding neighborhood visually or with odors or dust. Confining composting manure to small, aerated, movable bins concealed under dark green, non-reflective tarps is a good solution. Additional bins can be purchased and put into use as needed. There may be an experiment in the future with growing edible mushrooms in the bins using the partially composted manure and wood shavings bedding. There may also be a test of wood pellet bedding in the stalls, since this material composts better than wood shavings, and less material is used in the stalls to begin with. The compost is to be used at a native plant nursery at the site and as a soil amendment for plantings around the ranch.

4.4 Case Study #5

Site/Facility Description

This stable worked with their local RCD and boards 60-70 horses on site.

Composting System

The project is utilizing a concrete pad that formerly served as the floor for a pig rearing facility. The surface is uneven, and in order to have an adequate sized surface an additional 15 x 80 foot section was constructed with a compacted, low permeability crushed granite material. The operating pad measures approximately 80 feet by 80 feet. The pad has a variable slope up to approximately 2%, that drains surface water runoff into adjacent detention ditches and a small holding basin on the southwest corner of the pad. The ditches and basin are constructed with erosion control fabric and gravel. The site is located well out of and above the flood plain of the creek and away from the stables. An irrigation reservoir is located adjacent to the site.

The manure is composted using an aerobic thermophilic process using a front-end loader for turning and aeration. The manure and bedding (wood shavings) is collected at two storage bunkers adjacent to the stalls and paddocks. The storage bunkers have concrete floors with concrete walls on three sides. They are located away from the riparian area of the creek. The mixture is watered daily to ensure adequate starting moisture for composting. Manure is moved on a regular basis (every 1 to 5 days) to the composting site approximately 1500 feet away, where it is added to large piles or windrows that ultimately hold one month's worth of

material. Temperatures are monitored weekly until the compost is removed from the site. In order to minimize costs and loss of nitrogen, the piles are turned once a month. When necessary, water is applied with a 4 HP 2 inch gas pump that draws from a nearby irrigation reservoir. With each turning each month's pile is moved closer to a curing area located just off the main pad. After approximately 90 days of composting the material starts the curing or finishing process.

The active composting phase at this site is rather long due to the use of large quantities of wood shavings, particularly by the owners of show horses. This has been identified as a significant problem by the site facility manager as the long composting period reduces available space on the pad. As an alternative, the manager has begun to experiment with the use of wood pellets as a substitute for shavings. A comparison of composting and final compost quality will be made prior to the end of the demonstration phase of this project. The first product produced at the site is scheduled to be delivered and used by a local vegetable grower. A complete laboratory analysis of the compost will be provided to this cooperating grower. It will include analysis of nutrients, salinity, particle-size distribution, inert contaminants, maturity, and will be tested for the presence of viable weed seeds, heavy metals, and fecal coliform and Salmonella pathogens.

Prior Manure Management Methods

Prior to this demonstration project, the facility stored manure on site and then hauled all of its manure to the regional landfill at a cost of approximately \$20,000 per year. Manure from stalls and paddocks was held in a location too close to the creek and could potentially have caused a problem.

Evaluation and Comments From Owner/Manager

Thus far the manager is pleased with the potential for this manure management approach. The uneven concrete surface and compacted rock surface have hindered operations to a minor degree. The runoff retention structure has performed well even during a 4 inch rainfall event this winter. The manager sees a potential to both reduce the volume of waste through reduction in bedding materials and composting and reduce trucking costs for final disposal. Once the system is fully operational and all the bugs worked out, the operator believes that there will be an average of 4-6 hours a week of work plus another average of 8 hours a month to turn the compost piles. Time and costs associated with all aspects of this project are being recorded for final cost analysis.

5. GLOSSARY

aerobic – an organism or process requiring oxygen

aeration – to expose or supply with air

anaerobic – an organism or process that does not require oxygen

bedding manure – a mix of manure and bedding material

biofilter – a system that uses soil, organic materials, or living plants to trap unwanted gases, particulate matter or chemicals

buffer – any structure, distance, or planting that shields or protects another from danger, loss, or contamination

composted manure – manure that has gone through the composting process

containment area – a basin or other landscape feature designed to contain leachate or runoff from compost or manure handling areas

filter strip – typically an intentionally planted buffer area (grasses most often) that provides a trap for particulate matter and nutrients for runoff waters

fresh manure – manure that has been excreted from the horse within the previous 48 hours

grassed waterway – a vegetated drainage channel designed to safely carry water and trap sediment and nutrients

leachate – water passing through and out of soil or manure that contains dissolved nutrients and organic matter from the material

microbes – a microorganism (eg., bacteria, fungi, algae)

micronutrient – an element or compound required in only small amounts by animals and plants

pathogens – any disease-causing organism

pathogenic – disease-producing

riparian area – pertaining to the bank area adjacent to a creek, stream, or river

stored manure – manure that has been removed from stalls or paddocks and piled in preparation for further processing or disposal.

RCD – Resource Conservation District, a non-profit community organization organized as a Special District under California law (Division 9, Public Resource Code) that provides technical assistance for protection and conservation of natural resources

NRCS – National Resources Conservation Service, a branch of the United States Department of Agriculture (USDA) and formerly the Soil Conservation Service

6. REFERENCES

Land Application of Livestock and Poultry Manure (C.B. Hammond, Segars, and C. Gould) University of Georgia Extension <http://www.ces.uga.edu/pubcd/c826-w.html>

Small Ranch Manual. Nevada Cooperative Extension

Horse Manure Management. (J.G. Davis and A.M. Swinker). 1996. Colorado State University Cooperative Extension

Horse Manure Management. Council of Bay Area RCDs. 2000

Horse-Keeping on Small Acreage: protecting Groundwater and Surface Water. (B. Lamb and M. Sullivan) 1993. University of Rhode Island Cooperative Extension

On-Farm Composting Handbook. (Robert Rynk, ed.) 1992. Northeast Regional Agricultural Engineering Service

Strategies for Livestock Manure Management. Washington State University and King County Cooperative Extension. 2002

A Horse Owner's Guide to Protecting Massachusetts Natural Resources. 2003. www.state.ma.us/dep/consumer/animal.htm

Composting. Massachusetts Department of Environmental Protection. 2002

Horse Keeping: A Guide to Land Management for Clean Water. Bay Area RCDs. *Available from your RCD.*

Horse Manure Management. (R. James) Ohio State University Extension Fact Sheet (AGF-212-03).

Horse Manure Management-Preventing a Solid Nitrogen Deficiency. (R. James) Ohio State University Extension. Factsheet AGF-212-95 <http://ohioline.osu.edu/agf-fact/0212.html>

Horse Stable Manure Management. (E. Wheeler and J Zajaczkowski) Penn state Cooperative Extension. 2001

Manure Management. Clemson University Cooperative Extension Service. 1994.

Manure Management and Composting. Canadian Organic Growers. 1992

Manure and Pasture Management for Recreational Horse Owners. University of Minnesota Extension Service. 2000.

Spreading Manure on a Few Acres. University of Minnesota Extension Service. 2000.

Managing Manure by Composting. University of Minnesota Extension Service. 2000.

Manure Management for Horse Farms. (J. Gardner and R Wright). Ontario Ministry of Food and Agriculture. 1998

Ohio Livestock Manure and Wastewater Management Guide. Ohio State University. 1992.. Bulletin 604.

Passively Aerated Bunker System for Composting Horse Manure. (D. Shaw). Alberta Agriculture , Food, and Environment. 2002

Publications and Fact Sheets Available from your RCD:

An Overall Guide to Land Application of Horse Manure. Dennis Salisbury

Equine Manure Storage Fact Sheet

Equine Facility Site Assessment Checklist

Composting Horse Manure Fact Sheet

Manure Storage for Horse Facilities Fact Sheet

Managing Manure: The Role of Riparian Buffers

Land Application of Horse Manure Fact Sheet

Portable Backyard Garden

Photographic Monitoring

Water Quality Management and Horses

Web Sites:

Handling manure as a solid: <http://www.epa.gov/ostwater/guide/feedlots/execsumm.pdf> .

www.horsekeeping.com/horse_management/manure_management.htm Manure Management by Cherry Hill.

www.nps.ars.usda.gov/ Appendix F to CNMP show URL for that pg 6

www.agf.gov.bc.ca/resmgmt/fppa/pubs/environ/horse Environmental Guidelines for Horse Owners Ch.8. Manure Management

www.thehorse.com

McDowell, Agsource prepared by Larry Hudson, Extension Animal Scientist. 1998.

“Internal Parasites of Horses”

<http://mcdowell.ces.state.nc.us/staff/mdeluca/pages/horse.shtml>

www.californiastatehorsemen.com/envirohorse.htm

California Integrated Waste Management Board; Compost Regulations

www.ciwmb.ca.gov/regulations/title14/ch31.htm

7. SOURCES FOR FURTHER TECHNICAL ASSISTANCE

USDA-NRCS

925-371-0154	Alameda County
925-672-4577	Contra Costa County
707-794-1242 x 3	Marin/Southern Sonoma Counties
650-726- 4660	San Mateo County

County RCDs

Alameda County RCD
3585 Greenville Road, Suite 2
Livermore, CA 94550-6710
Phone (925) 371-0154 x 112
FAX (925) 371-0155
www.acrcd.org

Marin RCD
80 4th Street, Suite 203
Point Reyes Station, CA 94956
415-663-1170
www.sonomamarinrcds.org

San Mateo RCD
625 Miramontes St, Suite 103
Half Moon Bay, CA 94019
650-712-7765
www.sanmateorcd.org

Southern Sonoma County RCD
1301 Redwood Way, Suite 170
Petaluma, CA 94954
707-794-1242 x 3
www.sonomamarinrcds.org